

# Manual Jaw Crusher BB50



Translation

**Retsch**<sup>®</sup>

**Copyright**

© Copyright by  
Retsch GmbH  
Haan, Retsch-Allee 1-5  
D-42781 Haan  
Federal Republic of Germany



<b>1</b>	<b>Notes on the Operating Manual</b> .....	<b>6</b>
1.1	Explanations of the safety warnings .....	7
1.2	General safety instructions .....	8
1.3	Repairs.....	9
<b>2</b>	<b>Confirmation</b> .....	<b>10</b>
<b>3</b>	<b>Technical data</b> .....	<b>11</b>
3.1	Use of the machine for the intended purpose.....	11
3.1.1	Properties of the grinding material.....	11
3.2	Working instructions .....	12
3.3	Protective equipment .....	13
3.4	Emissions.....	13
3.5	Degree of protection .....	13
3.6	Motor rotation speed.....	13
3.7	Receptacle volume .....	13
3.8	Feed size .....	13
3.9	Rated power .....	14
3.10	Dimensions and weight.....	14
3.11	Required floor space.....	14
<b>4</b>	<b>Transport, scope of delivery, installation</b> .....	<b>15</b>
4.1	Packaging .....	15
4.2	Transport.....	15
4.3	Temperature fluctuations and condensed water .....	15
4.4	Conditions for the place of installation .....	15
4.5	Electrical connection .....	16
4.6	Type plate description.....	17
4.7	Removing Transport Safeguards.....	18
4.8	Removing the transport safeguard .....	19
4.9	Installation of the machine .....	19
<b>5</b>	<b>Operating the machine</b> .....	<b>20</b>
5.1	Views of the Instrument .....	20
5.2	Overview table of the parts of the device .....	21
5.3	Operating elements and displays .....	22
5.4	Overview Table of the Operating Elements and the Display.....	22
5.5	Switching On and Off.....	23
5.6	Setting the gap width to zero position.....	23
5.7	Setting the gap width .....	24
5.8	Reverse grinding.....	25
5.9	Setting the Speed .....	25
5.10	Starting the grinding process .....	26
5.11	Stopping the grinding process .....	26
5.12	Sample receptacle .....	27
<b>6</b>	<b>Safety functions and fault display</b> .....	<b>28</b>
6.1	Fault messages .....	28
<b>7</b>	<b>Cleaning, wear and service</b> .....	<b>29</b>
7.1	Cleaning.....	29
7.1.1	Removing the feed hopper .....	29
7.1.2	Removing the splash-back protection .....	30
7.1.3	Removing the grinding chamber cover .....	30
7.2	Service.....	30
7.2.1	Replacing the breaking jaws.....	31
7.2.2	Replacing the front breaking jaw .....	31
7.3	Wear .....	34
7.3.1	Resetting the wear alert.....	34

7.3.1.1	Setting the operating time until the calibration alert is displayed.....	34
<b>8</b>	<b>Disposal.....</b>	<b>36</b>
<b>9</b>	<b>Index .....</b>	<b>37</b>
<b>Appendix</b>	<b>.....</b>	<b>following page</b>

## 1 Notes on the Operating Manual

This operating manual is a technical guide on how to operate the device safely and it contains all the information required for the areas specified in the table of contents. This technical documentation is a reference and instruction manual. The individual chapters are complete in themselves.

Familiarity (of the respective target groups defined according to area) with the relevant chapters is a precondition for the safe and appropriate use of the device.

This operating manual does not contain any repair instructions. If faults arise or repairs are necessary, please contact your supplier or get in touch with Retsch GmbH directly.

Application technology information relating to samples to be processed is not included but can be read on the Internet on the respective device's page at [www.retsch.com](http://www.retsch.com).

### **Changes**

Subject to technical changes.

### **Copyright**

Disclosure or reproduction of this documentation, use and disclosure of its contents are only permitted with the express permission of Retsch GmbH.

Infringements will result in damage compensation liability.

## 1.1 Explanations of the safety warnings

In this Operating Manual we give you the following safety warnings

---

**Serious injury** may result from failing to heed these safety warnings. We give you the following warnings and corresponding content.

---

 **WARNING**

**Type of danger / personal injury**

Source of danger

- Possible consequences if the dangers are not observed.
  - **Instructions on how the dangers are to be avoided.**
- 

We also use the following signal word box in the text or in the instructions on action to be taken:

 **WARNING**

---

**Moderate or mild injury** may result from failing to heed these safety warnings. We give you the following warnings and corresponding content.

---

 **CAUTION**

**Type of danger / personal injury**

Source of danger

- Possible consequences if the dangers are not observed.
  - **Instructions on how the dangers are to be avoided.**
- 

We also use the following signal word box in the text or in the instructions on action to be taken:

 **CAUTION**

---

In the event of possible **property damage** we inform you with the word “Instructions” and the corresponding content.

---

*NOTICE*

**Nature of the property damage**

Source of property damage

- Possible consequences if the instructions are not observed.
  - **Instructions on how the dangers are to be avoided.**
- 

We also use the following signal word in the text or in the instructions on action to be taken:

*NOTICE*

## 1.2 General safety instructions

---

 **CAUTION****Read the Operating Manual**

Non-observance of these operating instructions

- The non-observance of these operating instructions can result in personal injuries.
- **Read the operating manual before using the device.**
- **We use the adjacent symbol to draw attention to the necessity of knowing the contents of this operating manual.**



**Target group :** All persons concerned with the machine in any form

This machine is a modern, high performance product from Retsch GmbH and complies with the state of the art. Operational safety is given if the machine is handled for the intended purpose and attention is given to this technical documentation.

You, as the owner/managing operator of the machine, must ensure that the people entrusted with working on the machine:

- have noted and understood all the regulations regarding safety,
- are familiar before starting work with all the operating instructions and specifications for the target group relevant for them,
- have easy access always to the technical documentation for this machine,
- and that new personnel before starting work on the machine are familiarised with the safe handling of the machine and its use for its intended purpose, either by verbal instructions from a competent person and/or by means of this technical documentation.

Improper operation can result in personal injuries and material damage. You are responsible for your own safety and that of your employees.

Make sure that no unauthorised person has access to the machine.

---

 **CAUTION****Changes to the machine**

- Changes to the machine may lead to personal injury.
- **Do not make any change to the machine and use spare parts and accessories that have been approved by Retsch exclusively.**

---

**NOTICE****Changes to the machine**

- The conformity declared by Retsch with the European Directives will lose its validity.
  - You lose all warranty claims.
  - **Do not make any change to the machine and use spare parts and accessories that have been approved by Retsch exclusively.**
-



### 1.3 Repairs

This operating manual does not contain any repair instructions. For your own safety, repairs may only be carried out by Retsch GmbH or an authorized representative or by Retsch service engineers.

**In that case please inform:**

The Retsch representative in your country
Your supplier
Retsch GmbH directly

**Your Service Address:**

--

## 2 Confirmation

This operating manual contains essential instructions for operating and maintaining the device which must be strictly observed. It is essential that they be read by the operator and by the qualified staff responsible for the device before the device is commissioned. This operating manual must be available and accessible at the place of use at all times.

The user of the device herewith confirms to the managing operator (owner) that (s)he has received sufficient instructions about the operation and maintenance of the system. The user has received the operating manual, has read and taken note of its contents and consequently has all the information required for safe operation and is sufficiently familiar with the device.

As the owner/managing operator you should for your own protection have your employees confirm that they have received the instructions about the operation of the machine.

I have read and taken note of the contents of all chapters in this operating manual as well as all safety instructions and warnings.

### User

Surname, first name (block letters)

Position in the company

Signature

### Service technician or operator

Surname, first name (block letters)

Position in the company

Place, date and signature

### 3 Technical data

#### 3.1 Use of the machine for the intended purpose

**Target group:** Operating company, operator

**Name of machine model:** BB 50

The jaw crusher has been specially developed for sample preparation in the laboratory. It is used for the fast and gentle grinding and pre-crushing of medium-hard, hard, brittle and tough materials.

The final fineness that can be achieved can be up to 0.5 mm or below depending on the feed material.

The maximum feed size is 40 mm.

Materials that can be ground in the BB 50 include the following:

Bakelite	Glass	Quartz
Bauxite	Limestone	Salts
Basalt	Ceramic	Fireclay
Concrete building materials	Gravel	Slag
Dolomite	Boneblack	Silicate
Ores	Coke	Silicon
Feld spar	Corundum	Sintered material
Granite	Alloys	Stones
Rubblestone	Oxide ceramic minerals	Cement clinker

##### 3.1.1 Properties of the grinding material

In principle every hard and brittle grinding material with hardness grade >3 according to the Mohs scale can be ground using this machine.

Damp, greasy grinding material and grinding material with a hardness grade <3 according to Mohs tends to compact or cake in the crushing chamber under the applied pressure. Grinding these products by fracturing and applying pressure is not possible.

Small sample quantities are ground gently and without loss. This machine is available with a grinding chamber made from ceramic materials for heavy metal-free grinding. The digital grinding gap display and the zero point alignment of the machine enable reproducible grinding results.

---

#### *NOTICE*

##### **Area of use of the machine**

- This machine is a laboratory machine designed for 8-hour single-shift operation.
  - **This machine may not be used as a production machine nor is it intended for continuous operation.**
-

**⚠ CAUTION**

**Risk of explosion or fire**

Changing sample properties

- The properties and therefore also the hazardousness of the sample can change during the grinding process.
- **Do not use any substances in this device which carry the risk of explosion or fire.**
- **Observe the material safety data sheets of the sample material.**

**3.2 Working instructions**

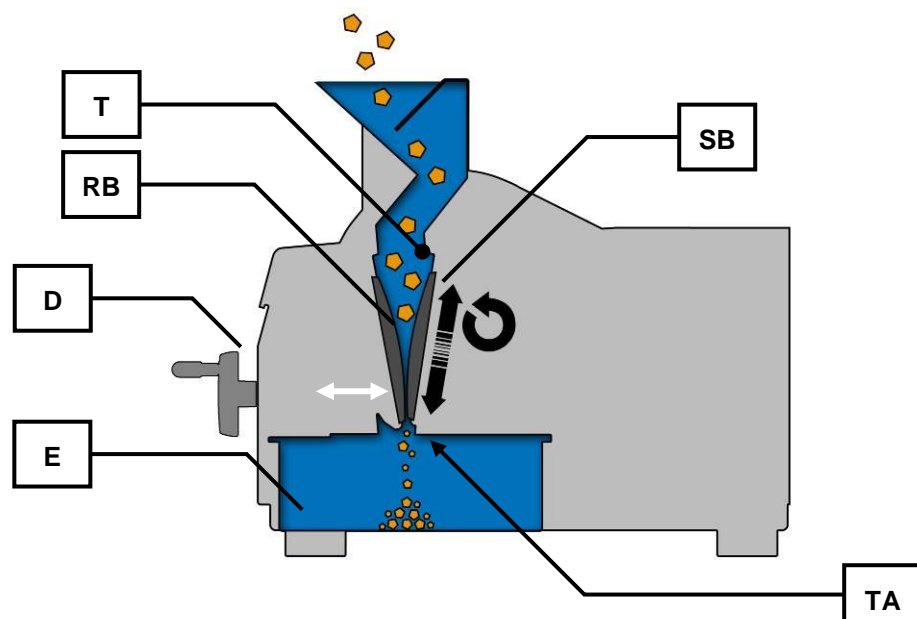

Fig. 1: Diagram of grinding

The grinding process in this machine takes place using pressure.

The grinding chamber (T) is funnel-shaped and narrows to the outlet opening (TA) depending on the set gap width.

The gap width setting is infinitely adjustable.

The machine has a stationary crusher arm (RB) connected to the gap width adjustment (D) and a mobile crusher arm (SB). Replaceable breaking jaws are attached to both crusher arms, between which the grinding takes place by means of pressure.

The eccentric movement of the actuated crusher arm (550...950/min) produces a constant conveying of the grinding material until the final fineness has been achieved that enables it to pass through the set gap (TA). It is then collected in a removable collecting receptacle (E).

The convex shape of the replaceable breaking jaws made from different materials ensures the best possible fine grinding and at the same time prevents material compaction and a bridging effect.

*NOTICE* If the crushing chamber (T) is filled with more than 2/3, then the fill hopper guide plates could be damaged; the moving breaker arm would force product behind the breaker arm and into the crusher housing.

### 3.3 Protective equipment

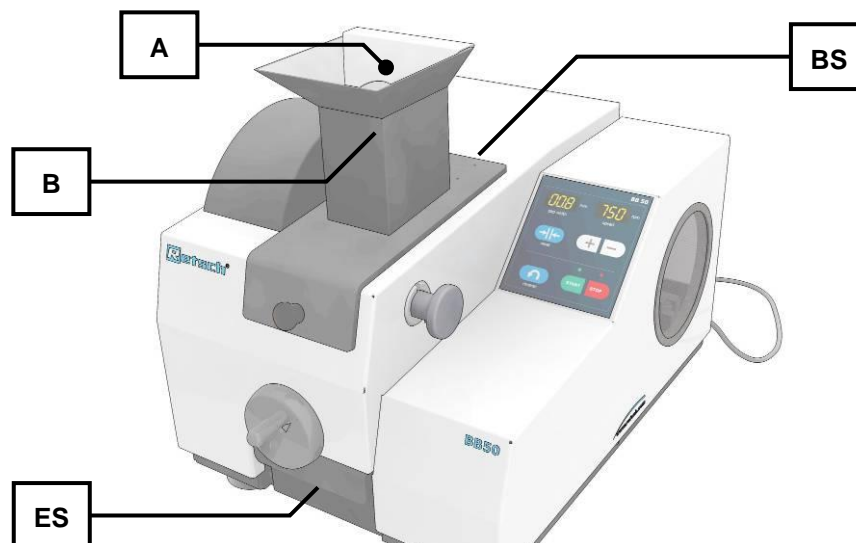

Fig. 2: Protective devices

The machine is equipped with the following protective devices:

A: Splash-back protection	Prevents sample ejection
B: Fill hopper	Protects against reaching inside the machine
BS: Switch for fill hopper	Checks position of the fill hopper and switches the drive off
ES: Switch for drawer	Checks drawer position

### 3.4 Emissions

Noise measurement

During grinding depending on the sample material:

- approx. 86,1 dB (A) without sample (speed 950 rpm)
- approx. 88,6 dB (A) with marble break (speed 650 rpm)

### 3.5 Degree of protection

- IP20

### 3.6 Motor rotation speed

The motor speed is 550...950min<sup>-1</sup> and can be adjusted in increments of 50.  
550 - 600 - 650 - 700 - 750 - 800 - 850 - 900 - 950min<sup>-1</sup>

### 3.7 Receptacle volume

The collection volume is < 3 l.

### 3.8 Feed size

The maximum feed size is 40mm.

### 3.9 Rated power

- 200-240 V: 1150W, 2 x 8A

### 3.10 Dimensions and weight

When closed:

Height: 463 mm

Width: 421 mm

Depth: 607 / 562 mm

Weight: approx. 76 kg

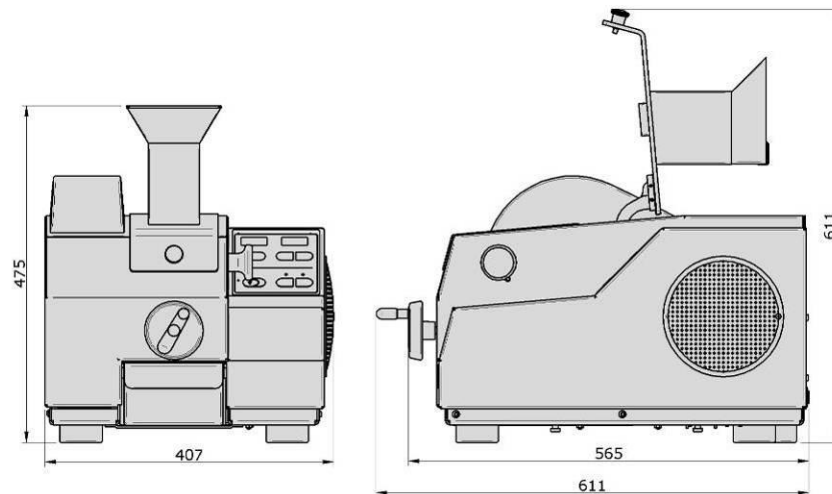

Fig. 3: Dimensions

### 3.11 Required floor space

607 mm (+ space for power plug) x 421 mm

- no safety distance necessary

Space is required in front of the machine to pull the drawer out.

## 4 Transport, scope of delivery, installation

### 4.1 Packaging

The packaging has been adapted to the mode of transport. It complies with the generally applicable packaging guidelines.

---

#### *NOTICE*

##### **Storage of packaging**

- In the event of a complaint or return, your warranty claims may be endangered if the packaging is inadequate or the machine has not been secured correctly.
  - **Please keep the packaging for the duration of the warranty period.**
- 

### 4.2 Transport

---

#### *NOTICE*

##### **Transport**

- Mechanical or electronic components may be damaged.
  - **The machine may not be knocked, shaken or thrown during transport.**
- 

### 4.3 Temperature fluctuations and condensed water

---

#### *NOTICE*

##### **Temperature fluctuations**

The machine may be subject to strong temperature fluctuations during transport (e.g. aircraft transport)

- The resultant condensed water may damage electronic components.
  - **Protect the machine from condensed water.**
- 

### 4.4 Conditions for the place of installation

Ambient temperature: 5°C to 40°C

---

#### *NOTICE*

##### **Ambient temperature**

- Electronic and mechanical components may be damaged and the performance data alter to an unknown extent.
  - **Do not exceed or fall below the permitted temperature range of the machine (5°C to 40°C / ambient temperature).**
-

Atmospheric humidity:

Maximum relative humidity 80% at temperatures up to 31°C, decreasing linearly up to 50% relative humidity at 40°C

---

### NOTICE

#### Atmospheric humidity

- Electronic and mechanical components may be damaged and the performance data alter to an unknown extent.
  - **Do not exceed the admissible range for atmospheric humidity.**
- 

## 4.5 Electrical connection

### WARNING

When connecting the power cable to the mains supply, use an external fuse that complies with the regulations applicable to the place of installation .

- Please check the type plate for details on the necessary voltage and frequency for the device.
  - Make sure the levels agree with the existing mains power supply.
  - Use the supplied connection cable to connect the device to the mains power supply.
- 

### NOTICE

#### Electrical connection

- Mechanical or electronic components may be damaged.
  - **Please observe the information on the type plate.**
- 

### NOTICE

#### Installation of the machine

- It must be possible to disconnect the machine from the mains at any time.
  - **Install the machine such that the connection for the mains cable is easily accessible.**
-



4.6 Type plate description

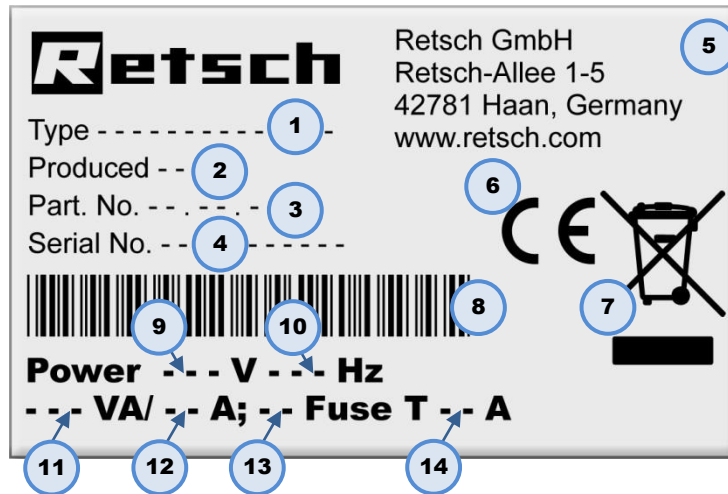

Fig. 4: Type plate lettering

- 1 Device designation
- 2 Year of production
- 3 Part number
- 4 Serial number
- 5 Manufacturer's address
- 6 CE marking
- 7 Disposal label
- 8 Bar code
- 9 Power version
- 10 Mains frequency
- 11 Capacity
- 12 Amperage
- 13 Number of fuses
- 14 Fuse type and fuse strength

In the case of questions please provide the device designation (1) or the part number (3) and the serial number (4) of the device.

#### 4.7 Removing Transport Safeguards

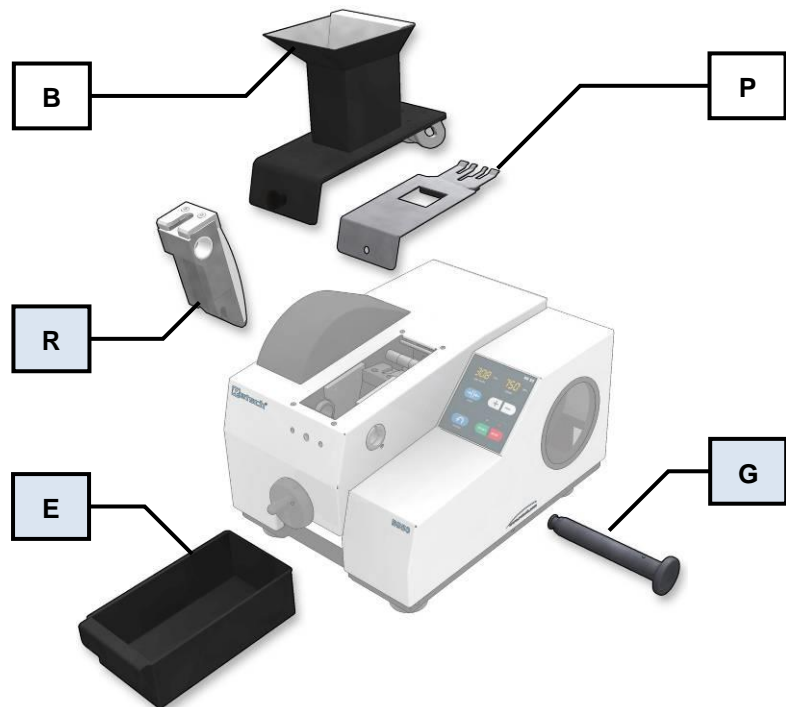

Fig. 5: Carrying the machine - preparation

- Before installing the carry support, remove the hopper (**B**) and the grinding room cover (**P**).  
(see chapter Cleaning → removing the fill hopper / removing the splash-back protection)
- Before carrying the machine, remove the bolt (**G**), the crusher arm (**R**) and the drawer (**E**) to make the machine lighter.  
(see chapter Servicing → replacing the breaking jaws)



Fig. 6: Mounting the transport aid

- Fix the two transport aids (**W**) using screws (**WS**) to the machine.

#### 4.8 Removing the transport safeguard

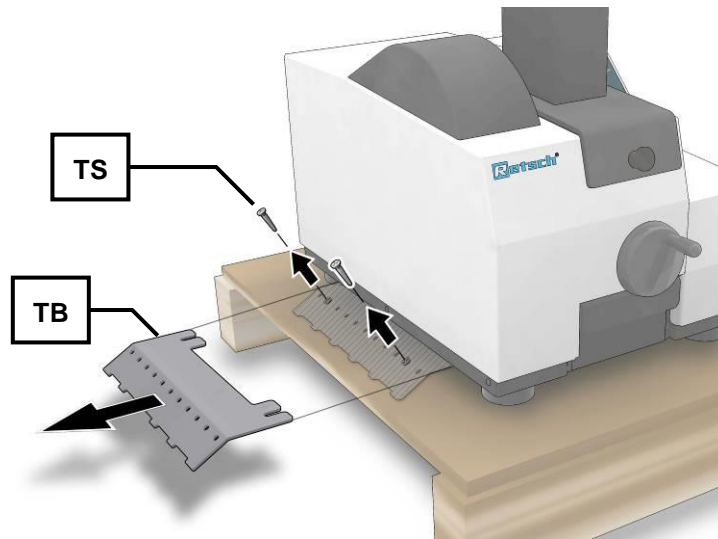

Fig. 7: Removing the transport lock  
 The machine is secured by steel plates on both sides.

- Remove the two screws (**TS**).
- Pull the transport lock (**TB**) out sideways.

#### 4.9 Installation of the machine

Installation height: maximum 2000 m above sea level

## 5 Operating the machine

### 5.1 Views of the Instrument

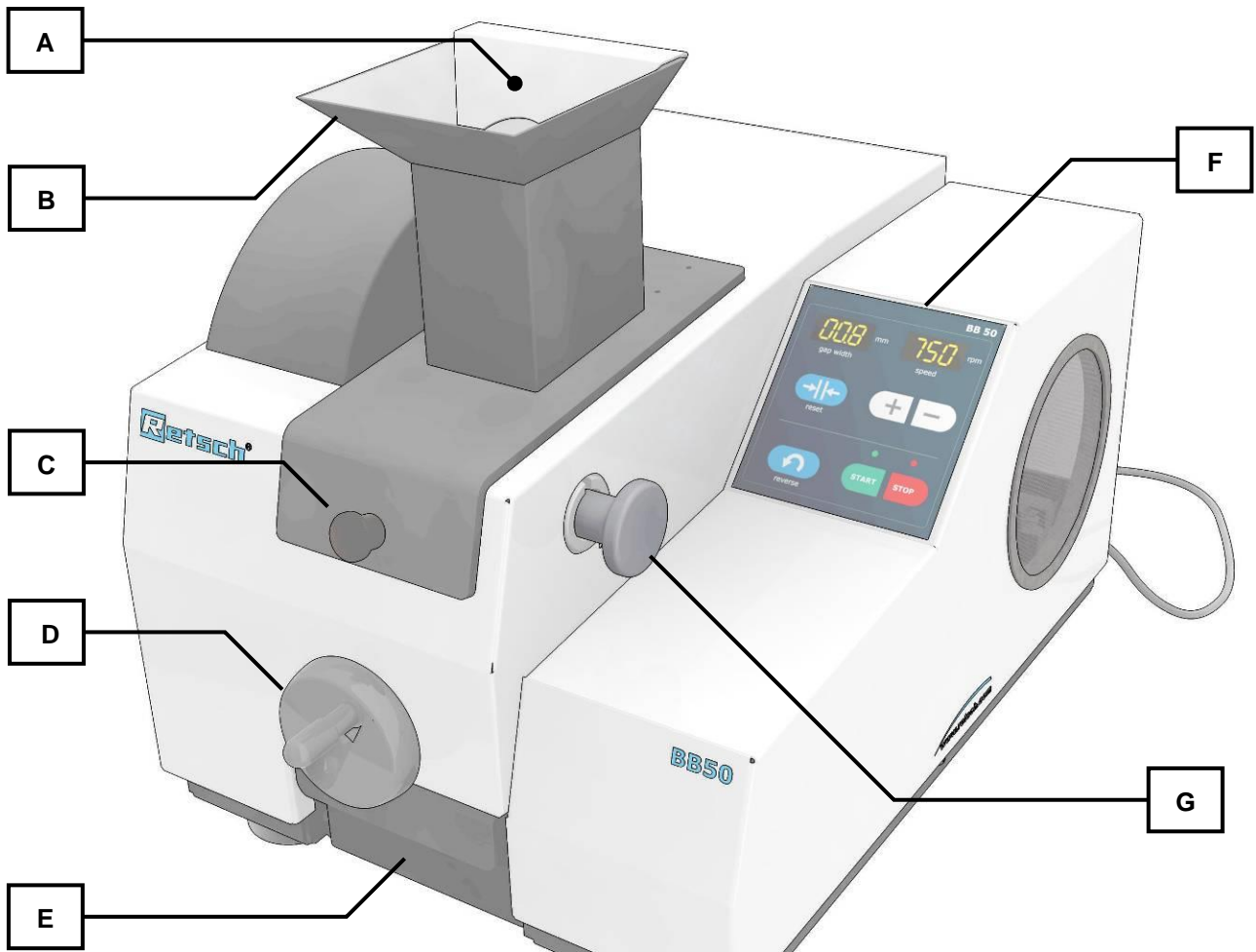

Fig. 8: Front view

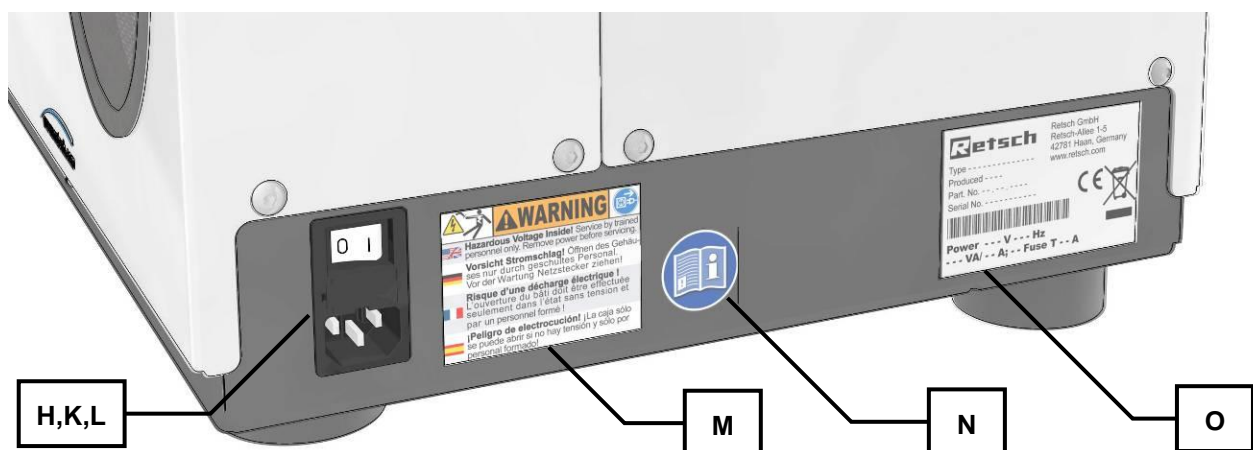

Fig. 9: Rear view

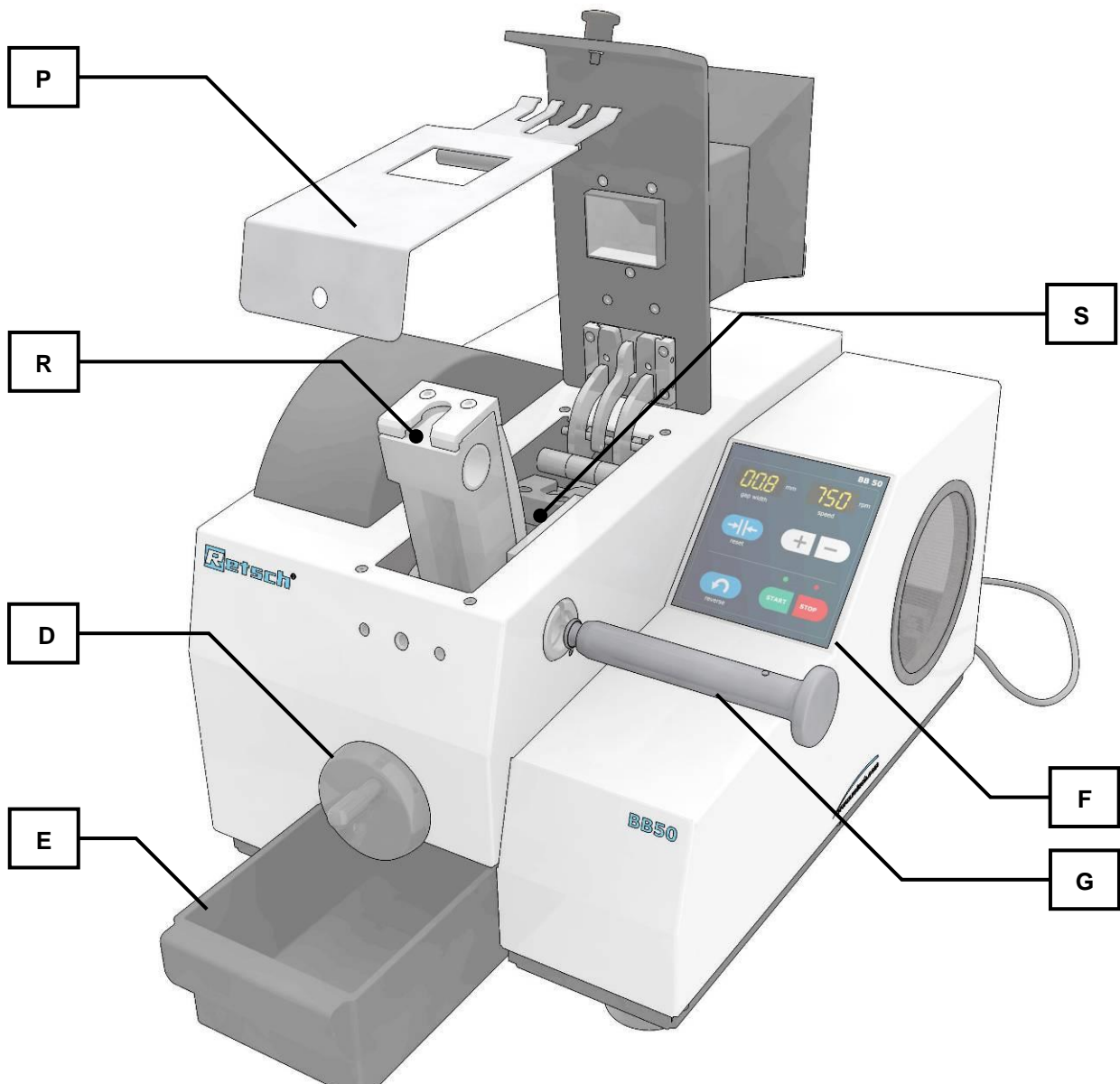

Fig. 10: Machine partially open

## 5.2 Overview table of the parts of the device

Element	Description	Function
A	Splash-back protection	Prevents sample ejection
B	Fill hopper	Receives the grinding material
C	Release handle	Releases the folding hopper
D	Hand wheel with folding handle	Setting the gap width
E	Drawer	Receives the ground sample material
F	Operator panel and display	(see below)
G	Bolt for front crusher arm	Holds the front crusher arm
H	On and off switch	Disconnects the controller from or connects it to the mains.
K	Machine fuse	Overload protection. Disconnects the motor from the mains in the event of overload.

L	Mains connection	Connection for power supply
M	Warning sign	Caution electric shock! Housing may only be opened by trained staff. Pull the mains plug before servicing!
N	Instruction to read the operating manual	Read the operating manual before putting into operation!
O	Type plate	Machine designation
P	Grinding chamber cover	Dirt protection, dust protection
R	Front crusher arm (shown partially pulled out)	Support for front breaking jaw
S	Rear crusher arm (hidden)	Support for rear breaking jaw

### 5.3 Operating elements and displays



Fig. 11: View of the operator panel and displays

### 5.4 Overview Table of the Operating Elements and the Display

Element	Description	Function
F1	Display of the gap width in mm	Displays the gap width
F2	Display of the speed	Number of crushing jaw lifts per minute
F3	Gap width zeroing	Zero value setting on crushing jaw contact
F4	+ and - buttons	Setting the crushing jaw speed
F5	Reverse running	Dislodging or loosening a sample blockage
F6	START and STOP buttons	Starting and stopping the motor

### 5.5 Switching On and Off

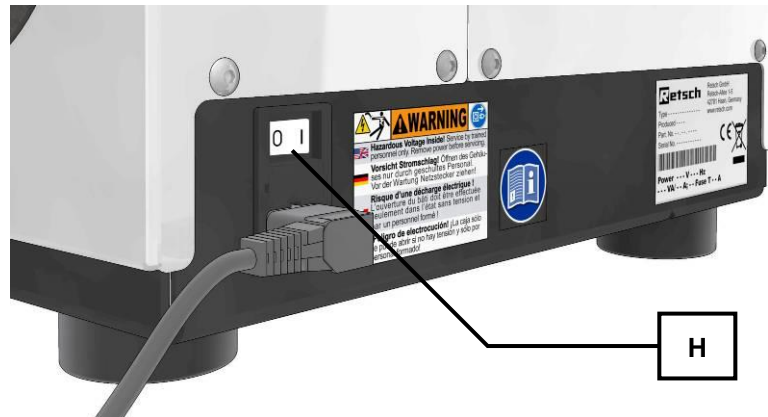

Fig. 12: Switching on / off

- The main switch (**H**) can be found on the back of the machine.
- Switch the main switch (**H**) on.
- The displays for the gap width and the speed light up.
- The machine is ready to use.

### 5.6 Setting the gap width to zero position

*NOTICE*

The gap width may only be adjusted during idling without grinding material. Grinding material may be neither in the crushing chamber nor in the fill hopper.

The breaking jaws may not have any contact so as to prevent a blockage and the associated potential damage to the breaking jaws.

Preparation:

- Switch the machine on at the main switch.
- Remove all grinding material from the fill hopper and crushing chamber.

When aligning the gap width, the breaking jaws must not demonstrate any contact to each other when beginning the adjustment.

- Before starting the machine, twist the hand wheel (**D**) 2 revolutions in an anti-clockwise direction.

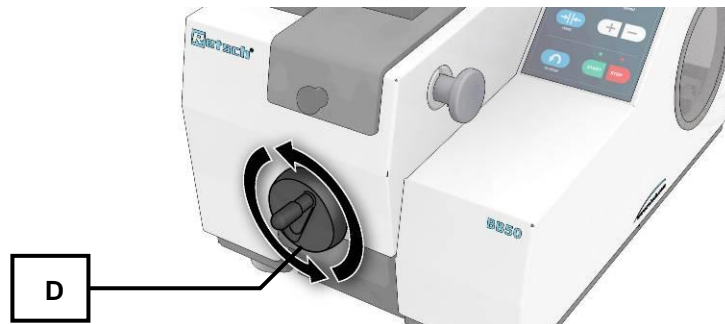

Fig. 13: Aligning the gap width

- Start the machine by pressing the START button (**F6**)
- Turn the hand wheel (**D**) clockwise until a clicking acoustically signals the contact of the crusher arms.
- Press the button (**F3**).

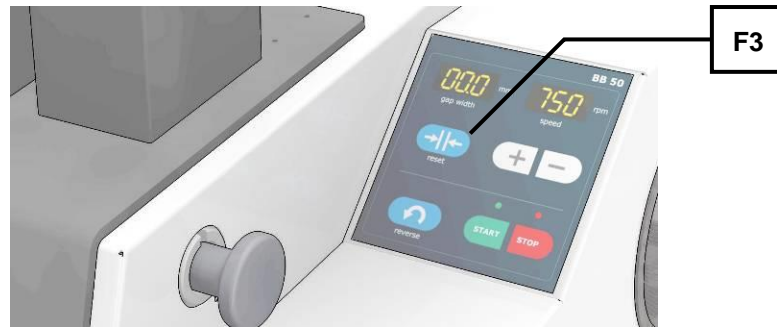

Fig. 14:

The display (F1) shows 00.0. The current gap width and the display therefore match.

The wear of the breaking jaws is not recorded by the gap width measurement. For this reason the alignment of the gap width should be performed regularly in order to guarantee matching between the information in the display and actual gap width.

The greater the load on the BB 50 and the harder and more abrasive the grinding material, the more frequently a zero point alignment to compensate for wear is required.

The reading in the display will otherwise not correspond to the actual gap width.

### 5.7 Setting the gap width

*NOTICE*

Before starting the machine, do not put any grinding material in the grinding chamber or fill hopper. This can lead to a blockage and cause damage to mechanical components.

- You can **reduce** the gap width (**sw**) with a twist of the hand wheel (**D**) **in a clockwise direction**.



- You can **increase** the gap width (**sw**) with a twist of the hand wheel (**D**) **in an anti-clockwise direction**

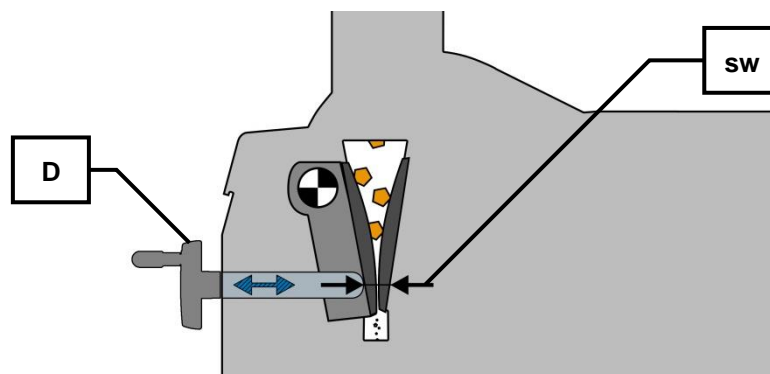

Fig. 15: Gap width



### 5.8 Reverse grinding

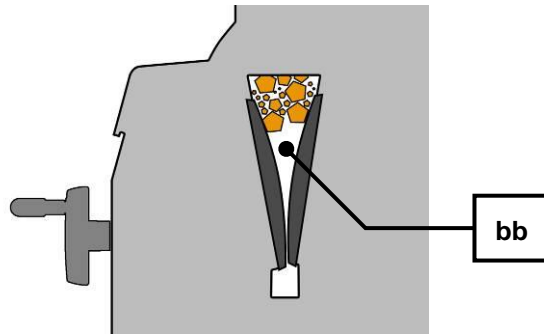

Fig. 16: Bridging effect in the grinding chamber

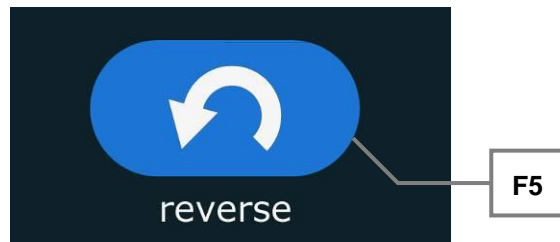

Fig. 17: Reverse button

Using the reverse function you can release grinding material in the event of a blockage in the machine or of bridging.

- Stop grinding.
- Press the reverse button (F5).

The machine will run backwards as long as you keep the reverse button pressed, and wedged material will be dislodged.

### 5.9 Setting the Speed



Fig. 18: Setting the speed

- Switch the machine on at the main switch.

The selectable grinding speed lies between 550 and 950 revolutions per minute

- Briefly press button (F4 +) to increase the speed in increments of 50.
- Briefly press button (F4 -) to decrease the speed in increments of 50.

When pressed for longer the speed levels are run through quickly. The display shows the last value which is updated when the button is released.

### 5.10 Starting the grinding process



Fig. 19: Start grinding

**NOTICE** The BB 50 may be started only when the crushing chamber and fill hopper are empty. Product which is present in the crushing chamber or fill hopper before starting will cause the machine to block and can cause damage to mechanical components.

- Press the START button (**F6**).  
The green LED above the START button lights up. The machine starts up.



Fig. 20: Gap width

- Adjust the gap width as required using the hand wheel (**D**).  
You can **reduce** the gap width (**sw**) with a twist of the hand wheel (**D**) **in a clockwise direction**.  
You can **increase** the gap width (**sw**) with a twist of the hand wheel (**D**) **in an anti-clockwise direction**.

The values on the display (**F1**) specify the gap width in mm. The display accuracy is  $\pm 0.1$ mm. The end of the grinding process may be recognised acoustically by a change in sound and the machine can be switched off.

### 5.11 Stopping the grinding process

**NOTICE**

Only interrupt the grinding if no more grinding material is in the fill hopper or crushing chamber. Mechanical components might be damaged by a blockage when starting up.

- Press the STOP button (**F6**).

The red LED above the STOP button lights up and the green LED above the START button goes out. The machine stops.

### 5.12 Sample receptacle



Fig. 21: Sample receptacle

## 6 Safety functions and fault display

### 6.1 Fault messages

Error code	DESCRIPTION	Display gap width	Display speed	
E 10	DRIVE OVERLOADED		E 10	Switch machine off and back on. Where necessary wait 10 minutes
E 22	ERROR KEYPAD		E 22	Switch machine off and back on.
E 26	ERROR FREQUENCY CONVERTER		E 26	Frequency converter is faulty. Service is required
E 50	ERROR SAFETY CIRCUIT		E 50	Safety circuit is faulty. Service is required
E 80	ERROR INTERFACE		E80	Communication fault in controller Service is required
H 41	CLOSE GRINDING CHAMBER		H41	Close hopper/drawer and press STOP
H 43	WEAR LIMIT REACHED		H 43	Replace breaking jaws
H 44	PLEASE CALIBRATE	PLS	CAL	Calibrate gap width
"Gap width" und "Speed" displays flash		88.8	888	Close hopper and drawer; restart the machine

## 7 Cleaning, wear and service

### 7.1 Cleaning

 **WARNING**

**Risk of a fatal electric shock**

- An electric shock can cause injuries in the form of burns and cardiac arrhythmia, respiratory arrest or cardiac arrest.
- **Do not clean the blender under running water. Use only a cloth dampened with water.**
- **Disconnect the power supply plug before cleaning the blender.**

#### 7.1.1 Removing the feed hopper

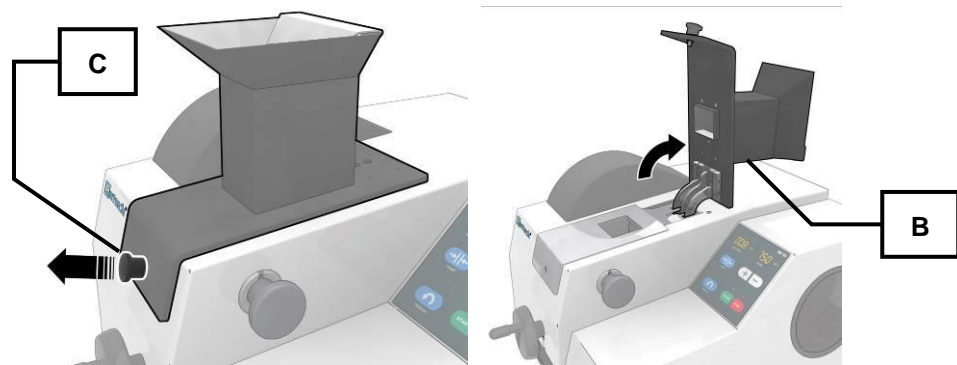

Fig. 1: Opening the hopper flap

- Pull the release handle (C) and fold back the fill hopper (B).

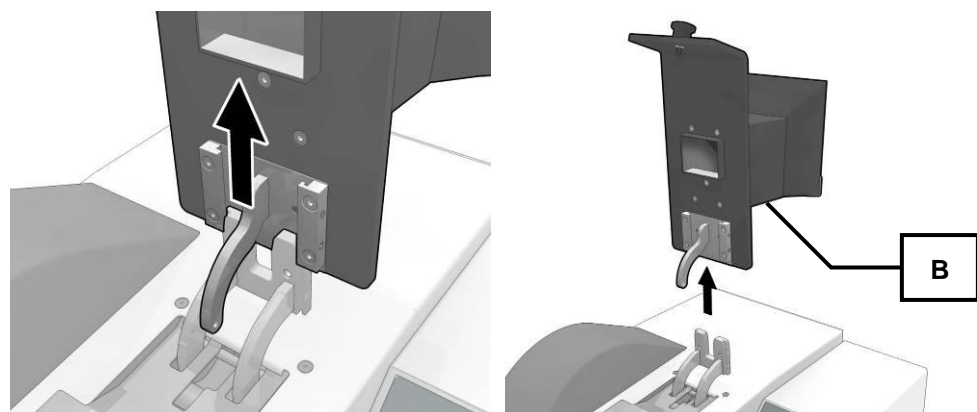

Fig. 2: Remove the hopper flap

- Pull off the fill hopper (B) against the resistance of the locks.

### 7.1.2 Removing the splash-back protection

**CAUTION**

1.V0072

**Risk of injury to eyes and skin**

Ejected sample material

- Sample material can be ejected from the machine if the splash-back protection is missing.
- **Never operate the machine without the splash-back protection.**

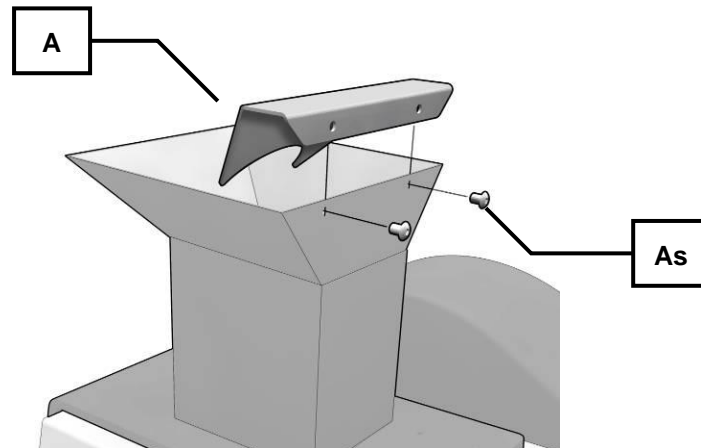

Fig. 22: Removing the splash-back protection

- Unscrew both screws (**As**).
- Remove the splash-back protection for cleaning (**A**).
- Secure the splash-back protection to the fill hopper again after cleaning.

### 7.1.3 Removing the grinding chamber cover

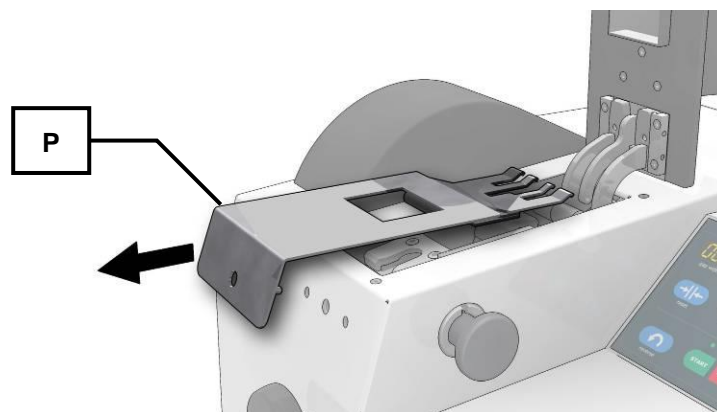

Fig. 23: Removing the grinding chamber cover

- Remove the grinding chamber cover (**P**) as shown in the above figure.

## 7.2 Service

This machine requires no servicing. When correctly used no adjustment work is required.

7.2.1 Replacing the breaking jaws

7.2.2 Replacing the front breaking jaw

*NOTICE*

Zircon breaking jaws (**ZB**) are bonded across the entire surface (**ZV**).

- Have the zircon breaking jaws replaced by an authorised service technician.

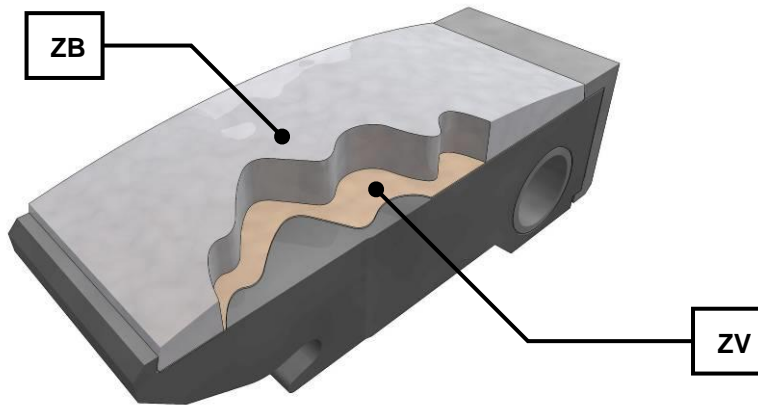

Fig. 24: Bonding the zircon breaking jaws

- Empty the grinding chamber before replacing the breaking jaws.
- Set the gap width to between 2 and 10 mm.

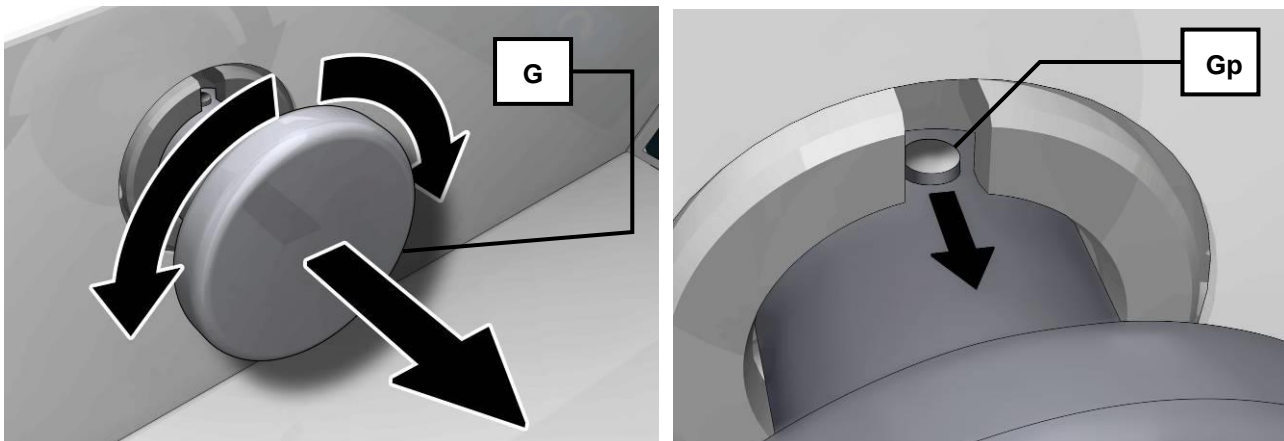

Fig. 25: Removing the bolt

- Twist the grip of the bolt (**G**) until the locking pin (**Gp**) can be seen in the top opening of the guide.

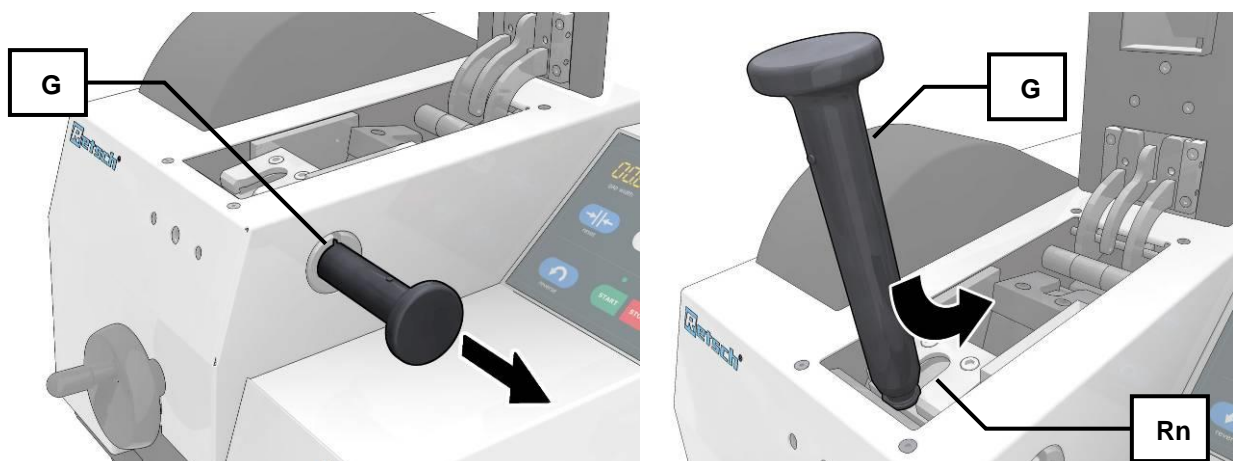

Fig. 26: Using the (bolt) removal tool

- Pull the bolt (**G**) out of the guide.
- Place the bolt (**G**) in the removal groove (**Rn**) of the front crusher arm.

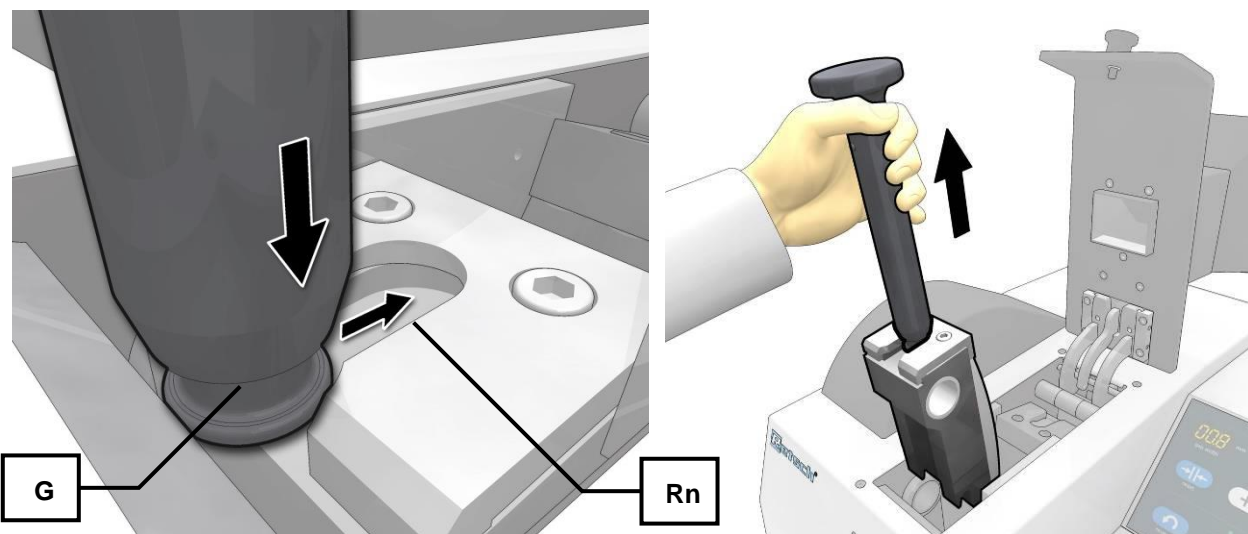

Fig. 27: Removing the breaking jaw

- Pull the crusher arm upwards out of the machine.

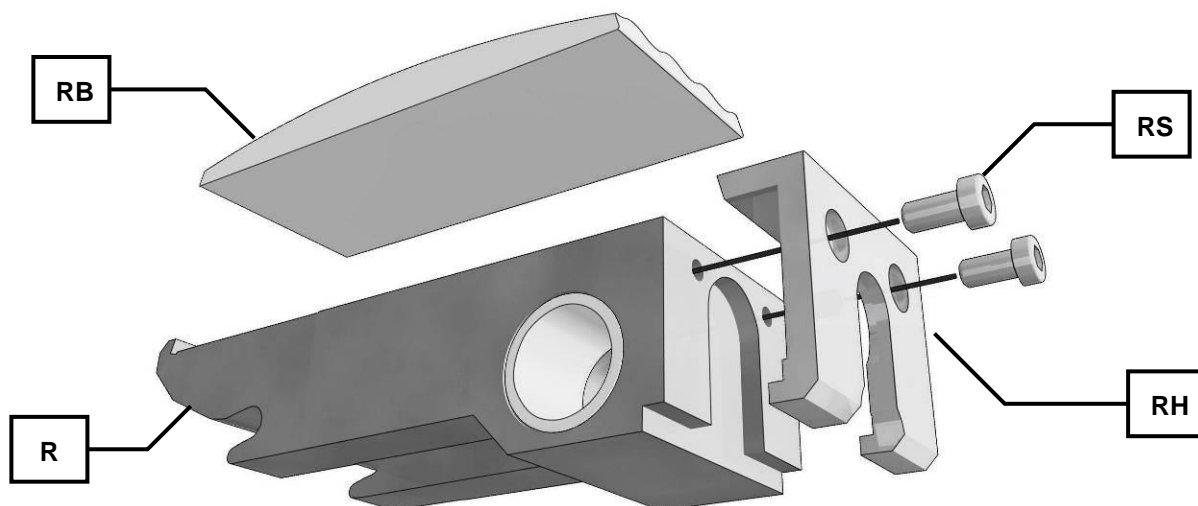

Fig. 28: Replacing the breaking jaw

- Unscrew the two screws (**RS**).
- Remove the retaining plate (**RH**)
- Replace the breaking jaw (**RB**).



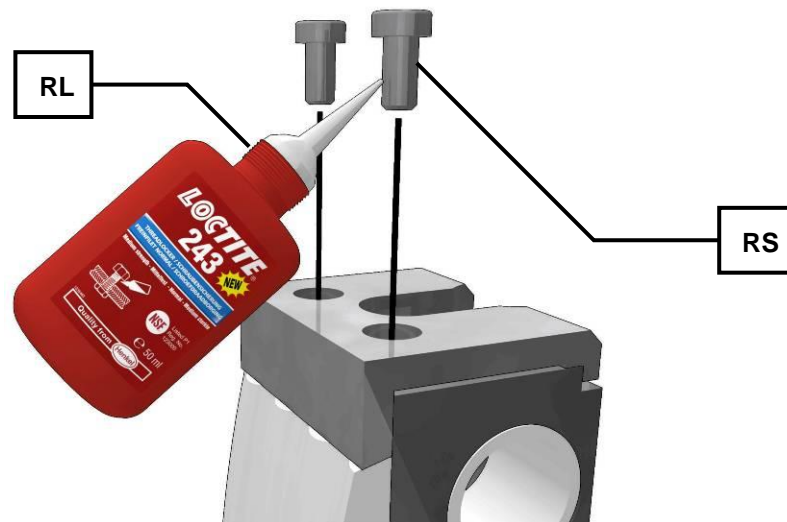

Fig. 29: Screw securing adhesive

- Use two new screws (**RS**) for installation or secure both screws with liquid screw securing adhesive (**RL**).

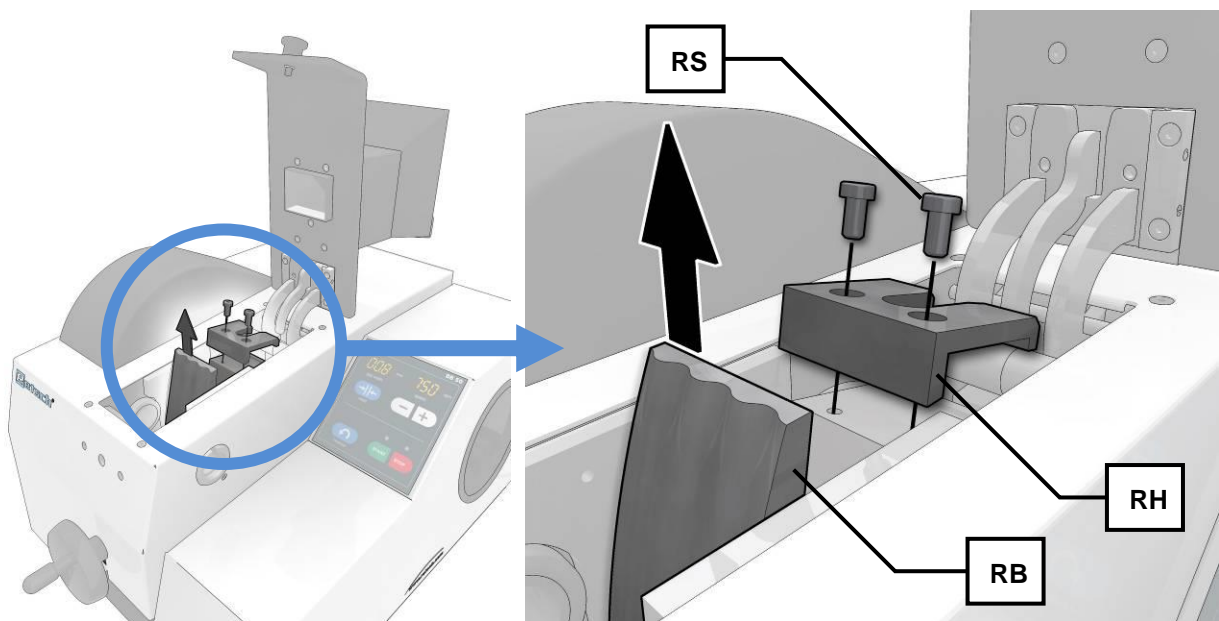

Fig. 30: Replacing the rear breaking jaw

The rear breaking jaw is replaced directly in the machine. The rear crusher arm remains in the machine in the process.

- Unscrew the two screws (**RS**).
- Remove the retaining plate (**RH**)
- Replace the breaking jaw (**RB**).

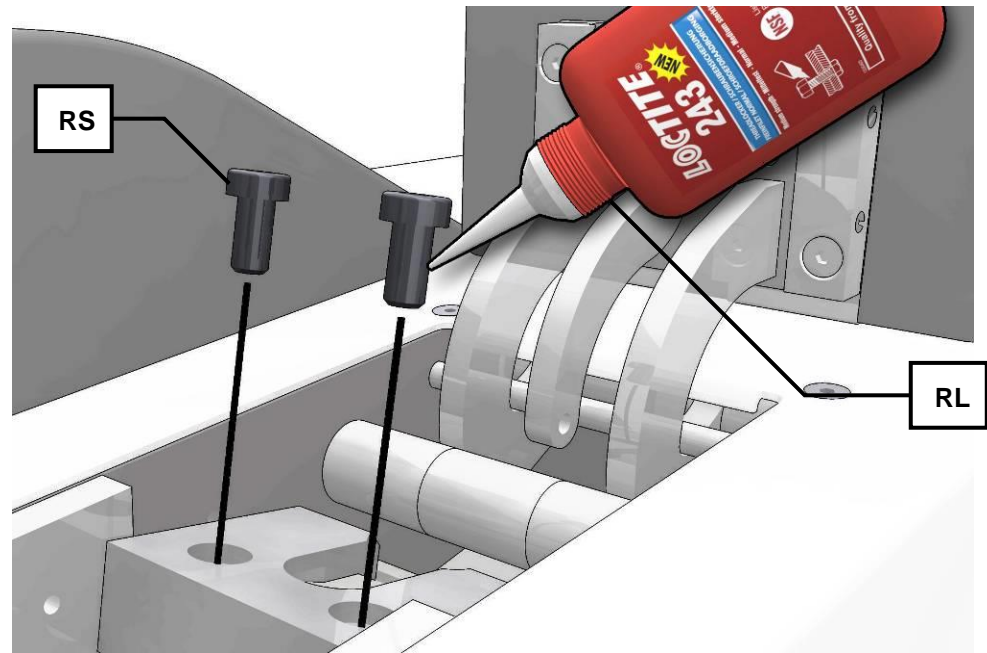

Fig. 31: Screw securing adhesive

- Use two new screws (**RS**) for installation or secure both screws with liquid screw securing adhesive (**RL**).

## 7.3 Wear

### 7.3.1 Resetting the wear alert

*NOTICE*

After replacing the breaking jaws, the wear warning should be reset.



Fig. 32: Wear alert

The wear alert (**F42**) appears when the breaking jaws are worn.

The currently set gap width flashes in the **gap width** (**F1**) display and the error code H43 is displayed in the **speed** (**F2**) display.

- Press the **STOP** button.

#### 7.3.1.1 Setting the operating time until the calibration alert is displayed

You can set the time until the calibration reminder appears. The time until the next calibration depends on the sample material and application.

- Press the STOP button (**F6**).
  - Simultaneously press the buttons **RESET+STOP** for 2 seconds.
- The currently set operating time until calibration flashes in the **gap width (F1)** display (default: 50h) and **h** is displayed in the **speed (F2)** display.
- Briefly press the button (**F4 +**) to increase the operating time in increments of 10.
  - Briefly press the button (**F4 -**) to decrease the operating time in increments of 10.



Fig. 33: Operating time until the calibration alert

## 8 Disposal

Please observe the respective statutory requirements with respect to disposal.

Information on disposal of electrical and electronic machines in the European Community.

Within the European Community the disposal of electrically operated devices is regulated by national provisions that are based on the EU Directive 2002/96/EC on Waste Electrical and Electronic Equipment (WEEE).

Accordingly, all machines supplied after 13.08.2005 in the business-to-business area to which this product is classified, may no longer be disposed of with municipal or household waste. To document this they have the following label:

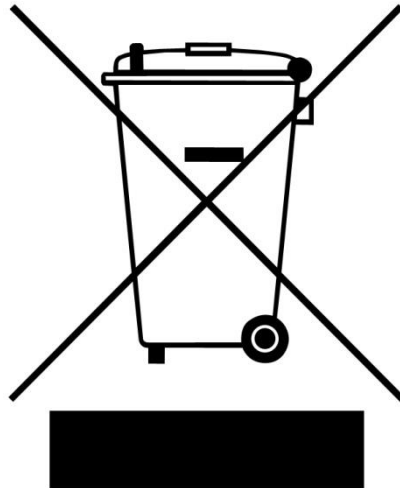

Fig. 34: Disposal label

Since the disposal regulations within the EU may differ from country to country we would request you to consult your supplier.

## 9 Index

### 8

88.8/888 28

### A

Aligning the gap width 23

Ambient temperature 15

Amperage 17

Atmospheric humidity 16

### B

Bar code 17

Bonding 31

Bridging effect 25

### C

CAL 28

Calibration alert 35

Calibration reminder 34

Capacity 17

Carrying the machine - preparation 18

CE marking 17

Changes 6

Cleaning 29

Cleaning, wear and service 29

collection volume 13

Conditions for the place of installation 15

Confirmation 10

Connection cable 16

Copyright 6

### D

Degree of protection 13

Device designation 17

Dimensions 14

Dimensions and weight 14

Disposal 36

Disposal label 17

Disposal label 36

### E

E10; E22; E26; E50 28

Electrical connection 16

Emissions 13

Error code 28

Explanations of the safety warnings 7

External fuse 16

### F

Fault messages 28

feed size 14

Feed size 14

Front view 20

funnel-shaped 12

Fuse strength 17

Fuse type 17

### G

Gap width 24

General safety instructions 8

Grinding process 12

Grinding speed 25

### H

H41; H43 28

### I

Installation height 19

Installation of the machine 19

IP20 13

### M

Mains frequency 17

Manufacturer's address 17

Maximum feed size 14

Maximum relative humidity 16

Moderate or mild injury 7

Motor rotation speed 13

Motor speed 13

Mounting the transport aid 18

### N

Noise measurement 13

Notes on the Operating Manual 6

Number of fuses 17

### O

Operating elements and displays 22

Operating the machine 20

Operating time until the calibration alert 34

Overview Table of the Operating Elements and the Display 22

Overview table of the parts of the device 21

### P

Packaging 15

Part number 17

PLS 28

Power version 17

property damage 7

Protective devices 13

Protective equipment 13

### R

Rated power 14

Rear view 20

Receptacle volume 13

Regulations for the place of installation 16

Removing the feed hopper 29

Removing the grinding chamber cover 30  
Removing the splash-back protection 30  
Removing the splash-back protection 30  
Removing the transport lock 19  
Removing the transport safeguard 19  
Removing Transport Safeguards 18  
Repairs 9  
Replacing the breaking jaws 31  
Required floor space 14  
Reverse 25  
Reverse grinding 25

## **S**

Safety functions and fault display 28  
Safety warnings 7  
Sample receptacle 27  
Screw securing adhesive 34  
Serial number 17  
serious injury 7  
Service 30  
Service Address 9  
Setting the gap width 24  
Setting the Speed 25  
Starting the grinding process 26  
Stopping the grinding process 26  
Switching On and Off 23

## **T**

Target group 8  
Technical data 11  
Temperature fluctuation and condensed water 15  
Transport 15  
Transport, scope of delivery, installation 15  
Type plate 16  
type plate description 17  
Type plate lettering 17

## **U**

Use of the machine for the intended purpose 11

## **V**

Views of the Instrument 20

## **W**

Wear 34  
Wear alert 34  
Working instructions 12

## **Y**

Year of production 17

## **Z**

Zero position 23  
Zircon breaking jaws 31







# JAW CRUSHER

BB 50 | 20.062.xxxx

## EU DECLARATION OF CONFORMITY

Herewith we declare, represented by the signatory, that the above mentioned device complies with the following directives and harmonized standards:

### Machinery Directive 2006/42/EC

Applied standards, in particular:

DIN EN ISO 12100	Safety of machinery
DIN EN ISO 13849-1	Safety of machinery - Safety-related parts of control systems
DIN EN 13683	Garden equipment - Integrally powered shredders/chippers – Safety
DIN EN 60204	Safety of machinery - Electrical equipment of machines

### EMC Directive 2014/30/EU

Applied standards, in particular:

DIN EN 55011	Industrial, scientific and medical equipment - Radio-frequency disturbance characteristics - Limits and methods of measurement
DIN EN 61000-3-3	Electromagnetic compatibility (EMC)
DIN EN 61326-1	Electrical equipment for measurement, control and laboratory use - EMC requirements

### Low Voltage Directive 2014/35/EU

Applied standards, in particular:

DIN EN 61010-1	Safety requirements for electrical equipment for measurement, control and laboratory use
----------------	--

### Authorized person for the compilation of technical documents:

Dr. Loredana Di Labio (technical documentation)

Furthermore, we declare that the relevant technical documentation for the above mentioned device has been compiled according to Annex VII Part A of the Machinery Directive, and we undertake to submit this documentation on request to the market surveillance authorities.

**In case of a modification of the device not previously agreed with Retsch GmbH, as well as the use of unauthorised spare parts or accessories, this declaration will lose its validity.**

Retsch GmbH

Haan, 08/2017



Dr. Ing. Frank Janetta, Team Leader R&D Department









**Copyright**

© Copyright by  
Retsch GmbH  
Haan, Retsch-Allee 1-5  
D-42781 Haan